

KEURIG®

K•Latte™

Use & Care Guide

Get the most from your new
Keurig® coffee maker

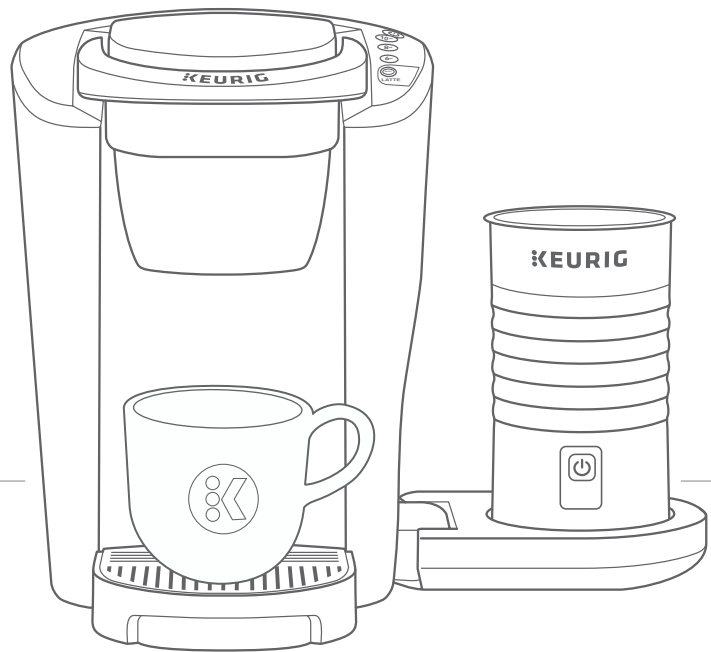

Before You Brew

1 Plug & Place

Remove packing tape from coffee maker and frother, and plug into a grounded outlet. Lower the frother base on the side of the coffee maker.

Place a large mug (296 ml/10 oz) on the drip tray.

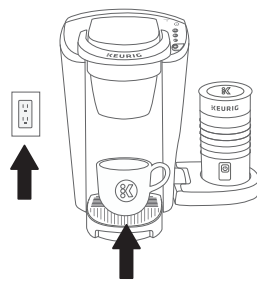

3 Clean the Frother

Remove the lid and whisk from inside the frother. Wash the interior of the frother, lid, and whisk with warm, soapy water. Dry all parts thoroughly using a soft, non-abrasive cloth, then reassemble.

NOTE: Frother is not dishwasher safe. Do not submerge frother in water. Only use non-abrasive cleaning materials to prevent damage to the inner surface of the frother. Dry interior of frother and base with a soft cloth after cleaning.

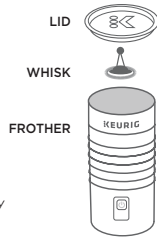

2 Rinse & Fill

Remove the water reservoir lid, then lift the reservoir straight up to remove it.

Rinse reservoir with fresh water and fill to the **MAX** fill line.

Replace water reservoir, making sure the lock tabs engage with the coffee maker. Replace lid.

NOTE: Do not use distilled water.

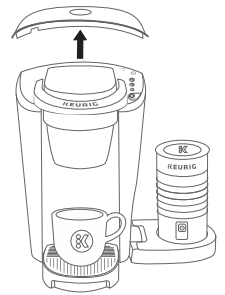

4 Power On

Press power button - the green power light will illuminate.

The coffee maker will automatically begin heating the water. This will take about 4 minutes. Once the heating sound stops, the coffee maker is ready.

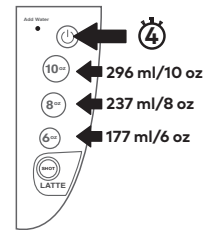

5 Cleansing Brew

Lift and lower the handle. **Do not insert a K-Cup® pod.** The three brew buttons and SHOT button will blink.

Press the **6 oz** button to start a cleansing brew. Pour the hot water into the sink.

The one-time setup process is now complete and you are ready to brew!

NOTE: Between brew cycles, the coffee maker may take about a minute to reheat.

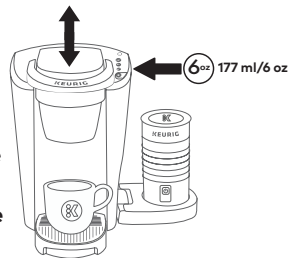

Make Your First Latte

1 Fill Frother

Remove lid and add chilled milk to the MAX line marked in the frother. Replace the lid and place the frother on the frother base.

Press the power button on the frother. The button will illuminate while heating - approximately 3 minutes. Frothing is complete when the button flashes and then turns off.

TIP: Having trouble frothing? We're here to help. Give us a call at 1-800-361-5628.

CAUTION: Frother is not microwave or dishwasher safe.

NOTE: Do not under or overfill frother. Do not operate before adding milk.

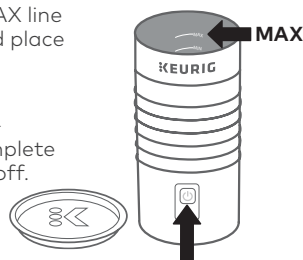

2 Place Mug & Pod

Place a mug on the drip tray. Lift the handle and place any K-Cup® pod in the K-Cup® pod holder. Lower the handle completely to close the lid.

Do not remove the foil lid on the K-Cup® pod.

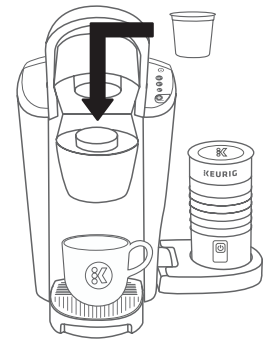

4 Create Your Latte

Remove the frother from the base. Remove the lid and pour the frothed milk over your shot of coffee.

NOTE: Clean frother immediately after use. For cleaning instructions, see Caring For Your Coffee Maker section in this guide.



3 Brew a Shot

The three brew buttons and SHOT button will blink. Press the **SHOT** button. Brewing is complete when the SHOT button is no longer illuminated. Lift the handle and recycle the used K-Cup® pod in 3 easy steps.

NOTE: After 60 seconds, the brew buttons will be disabled. To re-activate, lift and lower the handle completely.

CAUTION: While brewing, there is extremely hot water in the K-Cup® pod holder. To avoid injury, do not lift the handle during the brewing process.

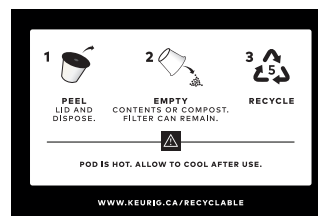
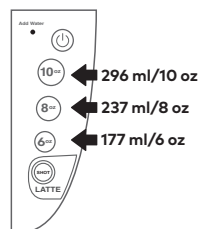

*Currently recyclable in select locations. Visit Keurig.ca/recyclable for more information.

Brew Your First Coffee

1 Place Mug & Pod

Place a mug on the drip tray plate. If using a travel mug, remove the drip tray and place the mug on the drip tray base. Lift the handle and place a K-Cup® pod in the K-Cup® pod holder. Lower the handle completely to close the lid.

Do not remove the foil lid on the K-Cup® pod.

High Altitude Brewing: While holding the coffee maker handle up, push down slowly on the K-Cup® pod in the pod holder until the bottom of the K-Cup® pod is punctured by the exit needle.

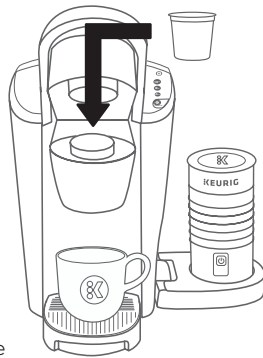

2 Brew & Enjoy!

Select your brew size. The button will remain illuminated while brewing — about 1 minute. Brewing is complete when the button is no longer illuminated. Lift the handle and recycle the used K-Cup® pod in 3 easy steps.

The coffee maker will be ready to brew another cup in about a minute.

NOTE: After 60 seconds, the brew buttons will be disabled. To re-activate, lift and lower the handle completely.

CAUTION: While brewing, there is extremely hot water in the K-Cup® pod holder. To avoid injury, do not lift the handle during the brewing process.

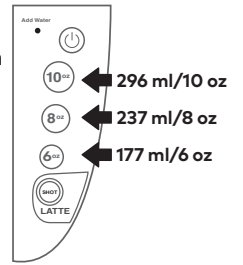

Coffee Maker Features

Frother froths milk to create your favourite latte.

SHOT button brews a shot of coffee to make delicious, creamy lattes.

Auto Off automatically turns your coffee maker off 2 hours after the last brew for energy savings.

Smart Start heats then brews in one simple process. No need to wait for the coffee maker to heat before selecting brew size. Power on your coffee maker, place mug, insert a K-Cup® pod, and lower the handle. Then, select your brew size. The coffee maker will heat, then automatically begin brewing.

Caring For Your Coffee Maker

Regular cleaning keeps your coffee maker running smoothly. Always be sure to turn off and unplug your coffee maker before cleaning.

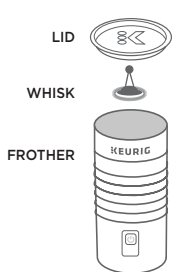

Frother

Clean immediately after each use and before first use.

To Clean:

1. Remove frother from the base, remove silicone ring from lid, and remove the whisk from inside the frother.
2. Wash the silicone ring, lid, and whisk with warm, soapy water.
3. Clean the interior of the frother with soap and rinse with warm water. Use a soft, non-abrasive cloth or sponge to prevent damaging the inner coating.
4. Wipe the exterior with a soft, damp cloth.
5. Dry all parts thoroughly and reassemble for next use.

NOTE: Frother is not dishwasher safe. Do not submerge frother in water. Only use non-abrasive cleaning materials to prevent damage to the inner surface of the frother.

Coffee Maker Exterior

Keep your Keurig® coffee maker looking its best by cleaning the exterior from time to time. Just clean with a damp, soapy, lint-free, non-abrasive cloth. Never immerse the coffee maker in water or other liquids.

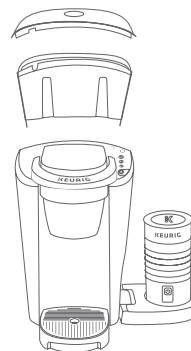
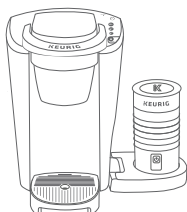

Water Reservoir & Reservoir Lid

The water reservoir lid and water reservoir should be cleaned periodically. Clean in a dishwasher (top rack only) or hand wash. To hand wash, use a damp, soapy, non-abrasive cloth. Rinse the reservoir thoroughly after cleaning. This will ensure that no cleaning solutions remain in the area as they may contaminate the water supply. After rinsing, fill the reservoir with clean water and return it to the coffee maker. Do not dry the inside of the water reservoir with a cloth as lint may remain. If needed, repeat above procedures.

NOTE: If you are using a water filter inside the water reservoir, remove it before cleaning.

Drip Tray

The drip tray can hold up to 237 ml/8 oz of overflow and should be emptied and cleaned occasionally. To remove, slide it toward you, keeping it level to avoid spilling. Clean in dishwasher (top rack only) or rinse and clean with a damp, soapy, lint-free, non-abrasive cloth.



Caring For Your Coffee Maker (Continued)

K-Cup® Pod Holder

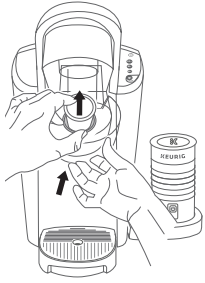

To remove the K-Cup® pod holder from the coffee maker, lift the handle and grasp the top of the K-Cup® pod holder with one hand while pushing up on the bottom of the K-Cup® pod holder from underneath with the other until it releases. After cleaning, align the K-Cup® pod holder with the opening using the two front ribs as a guide and snap into place from the top.

CAUTION: There are sharp needles that puncture the K-Cup® pod above the K-Cup® pod holder and in the bottom of the K-Cup® pod holder. To avoid risk of injury, do not put your fingers in the K-Cup® pod holder.

NOTE: Always remove and recycle the used K-Cup® pod after brewing.

Funnel

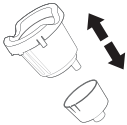

Washing the funnel ensures a fresh beverage experience. The funnel should be washed regularly and can be removed from the K-Cup® pod holder by pulling on it until it pops off. To replace it, orient the snaps to the indent and just snap it back onto the K-Cup® pod holder.

Exit Needle

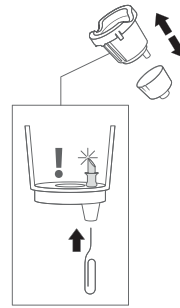

Remove the pod holder assembly and detach the funnel. Locate the exit needle on the inside bottom of the K-Cup® pod holder. Insert a straightened paper clip into the exit needle to loosen any coffee grounds.

Entrance Needle

Lift the coffee maker handle and locate the entrance needle on the underside of the lid. To clean both holes in the needle, hold the coffee maker handle in the upward position and with your other hand, carefully insert a straightened paper clip into both holes. Gently move it around to loosen any coffee grounds. Lower the handle completely and run two water-only brew cycles. Do not insert a K-Cup® pod.

TIP: Refer to keurig.ca for video instructions on cleaning the entrance/exit needles.

Descaling Your Coffee Maker

You should descale your coffee maker every 3-6 months. Properly follow the descaling procedure.

Depending on the mineral content of your water, calcium deposits or scale may build up in your coffee maker. Scale is non-toxic but if left unattended can hinder coffee maker performance. Regularly descaling your coffee maker every 3-6 months helps maintain the heating element, and other internal parts that come in contact with water. Calcium deposits may build up faster, making it necessary to descale more often.

Descaling Procedure

Before you begin, you will need a large ceramic mug, fresh water, Keurig® Descaling Solution, and access to a sink. Do not use a paper cup. Ensure that there is no beverage pod in the K-Cup® pod holder. Please allow approximately 45 minutes for the descaling procedure.

Empty the water from the water reservoir. If using a Keurig® Water Filter, remove and set aside.

STEP 1: Cleansing Rinse

Press the power button to power the coffee maker off.

Pour the entire bottle of Keurig® Descaling Solution into an emptied water reservoir. Then fill the empty bottle with water and pour into the water reservoir. Press the power button to turn the coffee maker back on.

Place a large mug on the drip tray and run a rinsing brew by lifting and lowering the handle and selecting the largest brew size.

STEP 2: Internal Tank Soak

Repeat the rinsing brew process until the add water light is illuminated. Do not use a K-Cup® pod. Let coffee maker stand for at least 30 minutes while still on.

After 30 minutes, discard any residual solution from the water reservoir and rinse thoroughly.

STEP 3: Fresh Water Rinse

Fill the water reservoir with fresh water to and not beyond the MAX fill line.

Place a large mug on the drip tray plate and run a rinsing brew using the largest brew size. Do not use a K-Cup® pod. Pour the contents of the mug into the sink.

Repeat brew process until you have completed at least 12 rinsing brews using the largest brew size. You may need to refill the water reservoir at least one time during this process.

NOTE: The cleaning action of Keurig® Descaling Solution may result in a "foam" dispensed from the coffee maker. This is natural, as the solution is reacting with the scale inside. For a coffee maker that is heavily scaled, the coffee maker may not fill properly after the descaler is added. If this occurs, you may see only a small or no output dispensed, followed by the sound of air blowing out. If this occurs:

- Turn off and unplug the coffee maker.
- If there is Keurig® Descaling Solution in the water reservoir, discard the contents, rinse the water reservoir thoroughly and refill with water.
- Plug the coffee maker back in, power on, and repeat the Step 3 Fresh Water Rinse cycle. The coffee maker should begin to function normally as the solution is rinsed out and the scale is removed. If problem persists, allow coffee maker to sit unplugged for at least 30 minutes before continuing with the rinse.

Troubleshooting

Frother

- If the milk you are using isn't frothing, please call Customer Service.
- If you are brewing coffee, you may not be able to use the frother at the same time. If you press the button on the frother and the light won't illuminate, wait 30 seconds after the coffee maker has finished brewing. Press the button on the frother again and the light will illuminate. If you still cannot use the frother, contact Customer Service.

Grounds in Your Coffee

- Grounds may have gathered in the exit or entrance needles and can be cleaned using a straightened paper clip or similar tool.
- Clean the exit needle of the K-Cup® pod holder. Refer to the Exit Needle care instructions.
- Clean the coffee maker entrance needle. Refer to the Entrance Needle care instructions.

Coffee Maker Will Not Brew

- After placing the K-Cup® pod in the K-Cup® pod holder, make sure that the handle is pushed down securely and the brew buttons are flashing.
- If the add water light is illuminated, add water to water reservoir. Fill to and not beyond the MAX fill line. Make sure the water reservoir is seated properly in its base. If the add water light continues to be illuminated even after refilling, contact Customer Service.
- If the small cup, small mug, large mug, and SHOT button lights are all on simultaneously, lift handle and remove K-Cup® pod (if present in the coffee maker). Close handle and place a large mug on the drip tray. Press the power button once. The coffee maker may dispense hot water.

- If the small cup, small mug, large mug, and SHOT button lights all blink simultaneously, contact Customer Service.
- If frother is in use, you may not be able to brew coffee at the same time. If this happens, wait 30 seconds after the frother has finished frothing then try brewing again. If you still cannot brew, contact Customer Service.

Brewing a Partial Cup

- The exit needle may be clogged. Refer to the Exit Needle care instructions.
- The water reservoir may have been removed during brewing. Replace the water reservoir and perform a rinsing brew without a K-Cup® pod.
- The coffee maker may need to be descaled. If you have repeated the descale procedure on your coffee maker two times and it is still only brewing a partial cup, contact Customer Service.

Coffee Maker Does Not Have Power or Shuts Off

- Make sure that the power button has been turned on.
- Plug coffee maker into its own grounded outlet. If the electric circuit is overloaded with other appliances, your coffee maker may not function properly. The coffee maker should be operated on its own circuit, separate from other appliances.
- For energy savings, the coffee maker automatically turns off 2 hours after the last brew. Press the power button and the green power light will illuminate.
- If the coffee maker still doesn't have power, contact Customer Service.

Helpful Hints

Water quality varies greatly. If you notice an undesirable taste in your beverage (such as chlorine or mineral tastes), we recommend using bottled or filtered water. Do not use distilled water. You can also install a Keurig® Water Filter to help remove water impurities and improve beverage taste.

Service

Beyond these recommended cleaning and maintenance procedures, this coffee maker is not user serviceable. For service, please refer to the Warranty section of this guide.

Storage

Empty the water reservoir before storing or transporting and take care to ensure that you store your coffee maker in a safe and frost free environment. Please be sure to store your coffee maker in its upright position to avoid water leakage from the inner tank. If you store the coffee maker in a cold environment, you run the risk of water freezing inside the coffee maker and causing damage. When you prepare to use it after storage, we recommend cleaning the water reservoir with soap and fresh water and descaling the coffee maker as detailed in the section above.

If you plan to move your coffee maker to a different location, turn the coffee maker off, unplug it, and empty the water reservoir. If your coffee maker has been in an environment below freezing, please be sure to let it warm to room temperature for at least 2 hours before using.

Click or Call!

Have Questions?

We're here to help. Visit keurig.ca for step-by-step videos on cleaning, descaling, and more.



Still Need Help?

Give us a call at
1-800-361-5628

Warranty

LIMITED ONE YEAR WARRANTY

Keurig Green Mountain, Inc. (Keurig) warrants that your coffee maker will be free of defects in materials or workmanship under normal home use for one year from the date of purchase. It is recommended that you register your coffee maker on keurig.ca/welcome so that your purchase information will be stored in our system. Keurig will, at its option, repair or replace a defective coffee maker without charge upon its receipt of proof of the date of purchase. If a replacement coffee maker is necessary to service this warranty, the replacement coffee maker may be new or reconditioned. If a replacement coffee maker is sent, a new limited one year warranty will be applied to the replacement coffee maker.

This warranty only applies to coffee makers operated in the United States and Canada. This warranty gives you specific legal rights, and you may also have other rights that vary from state to state and, in the case of Canada, from province to province.

Only the use of Keurig® K-Cup® brand pods and accessories will guarantee the proper functioning and lifetime of your Keurig® coffee maker. Any damage to or malfunction of your coffee maker resulting from the use of non-Keurig® pods and accessories may not be covered by this warranty or may result in a service fee if the damage or malfunction is determined to be caused by such use.

NOTE: FROTHER IS NOT INTENDED TO BE CLEANED IN A DISHWASHING MACHINE. WATER OR OTHER DAMAGE TO FROTHER SUSTAINED IN CLEANING OF FROTHER IS NOT COVERED BY THIS WARRANTY.

WHAT IS NOT COVERED BY THE LIMITED WARRANTY?

THIS WARRANTY DOES NOT COVER CONSEQUENTIAL OR INCIDENTAL DAMAGES SUCH AS PROPERTY DAMAGE AND DOES NOT COVER INCIDENTAL COSTS AND EXPENSES RESULTING FROM ANY BREACH OF THIS WARRANTY, EVEN IF FORESEEABLE. Some states or provinces do not allow the exclusion

or limitations of incidental or consequential damages, so the above limitation or exclusion may not apply to you depending on the state or province of purchase.

Nor does this warranty cover damages caused by use of non-Keurig® pods or accessories, services performed by anyone other than Keurig or its authorized service providers, use of parts other than genuine Keurig® parts, or external causes such as abuse, misuse, inappropriate power supply, or acts of God.

OTHER LIMITATIONS

THIS WARRANTY IS EXCLUSIVE AND IS IN LIEU OF ANY OTHER EXPRESS WARRANTY, WHETHER WRITTEN OR ORAL. IN ADDITION, KEURIG HEREBY SPECIFICALLY DISCLAIMS ALL OTHER WARRANTIES WITH RESPECT TO YOUR KEURIG® COFFEE MAKER, INCLUDING ANY IMPLIED WARRANTY OF MERCHANTABILITY OR FITNESS FOR ANY PARTICULAR PURPOSE. Some states or provinces do not allow disclaimers of such implied warranties or limitations on how long an implied warranty lasts, so the above limitation may not apply to you depending on the state or the province of purchase.

HOW DO YOU OBTAIN WARRANTY SERVICE?

Keurig® coffee makers are high-quality appliances and, with proper care, are intended to provide years of satisfying performance. However, should the need arise for warranty servicing, simply call Keurig Customer Service at our toll free phone number 1-800-361-5628. Please do not return your coffee maker for servicing without first speaking to Keurig Customer Service to obtain a Return Materials Authorization (RMA) number. Keurig® coffee makers returned without a RMA number will be returned to the sender without servicing.

K·Latte™

SINGLE SERVE COFFEE & LATTE MAKER

- A. K-Cup® Pod Holder
(A and B are the K-Cup®
Pod Holder Assembly)
- B. Funnel
- C. K-Cup® Pod Assembly
Housing
- D. Power Cord
- E. Drip Tray Plate
- F. Drip Tray
- G. Drip Tray Base
- H. Handle
- I. Water Reservoir Lid
- J. Water Reservoir
- K. Water Reservoir Lock
Tab Slots
- L. Frother Lid
- M. Frother Whisk
- N. Frother
- O. Frother Base

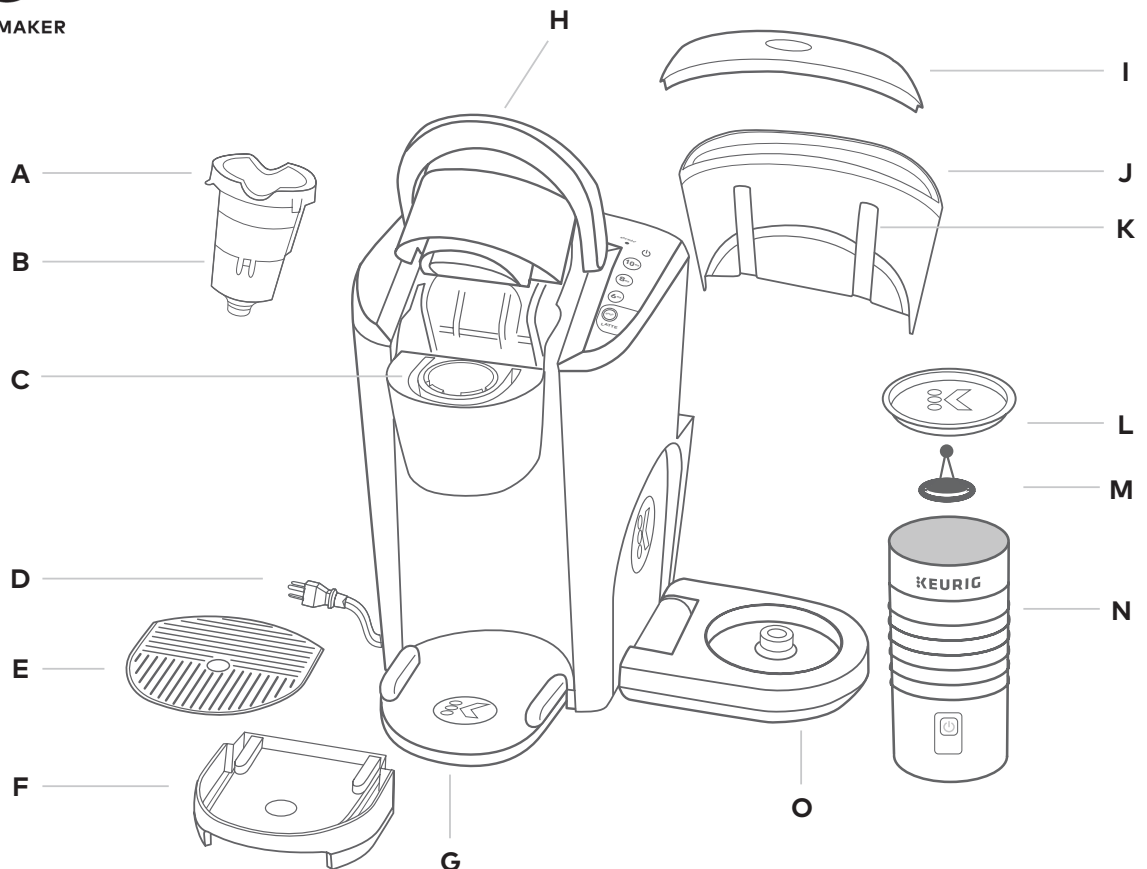

For replacement parts, please visit www.keurig.ca

**Coffeehouse taste
in your own home.**

**REGISTER YOUR NEW
KEURIG® COFFEE MAKER**

and receive a special savings offer. Restrictions
apply. See keurig.ca for details.

keurig.ca/welcome